

The Buried Diffuser

A real innovation for an efficient irrigation

December 2012

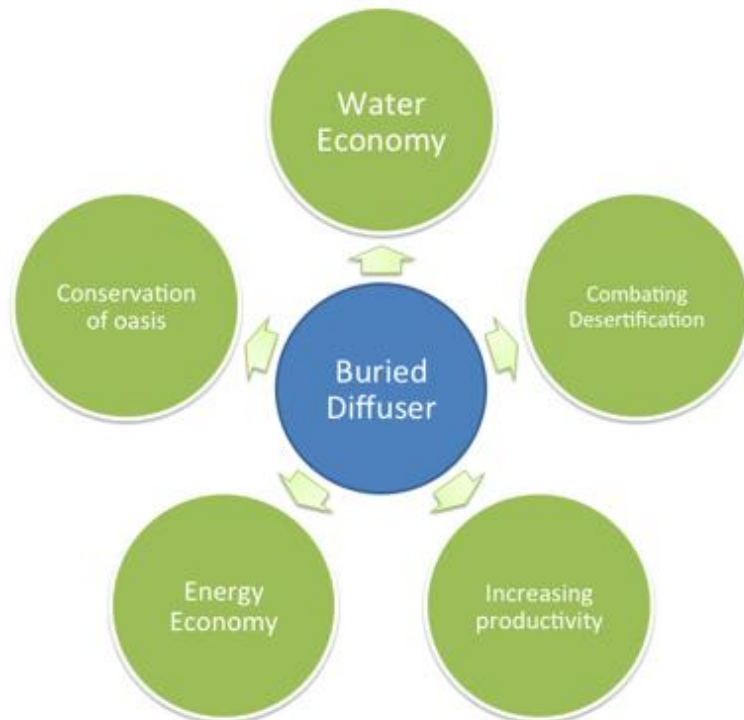

Chahbani Technologies - www.chahtech.com

→ Underground-localized Irrigation of Trees, Shrubs, Vegetables, landscaping and Plants in containers

→ Anticipated Irrigation and Injection of the dam's retention water, the natural spring's water and the water of rivers

CHAHTECH.SA

BP 466 - Houmt Souk – Djerba - 4180 Tunisia

Mobile: +216 98 254 383

Tel/Fax: +216 75 654 391

Website: www.chahtech.com

Email: contact@chahtech.com



CHAHTECH

More crop with less drop



The Buried Diffuser is, with no doubt, the most suitable irrigation technique to bring water to the tree roots.



I. INTRODUCTION

I. PRESENTATION OF THE BURIED DIFFUSER

- A. Irrigation of fruit trees, forest trees, ornamental trees and shrubs**
- B. Irrigation of vegetables in fields and in greenhouses**
- C. Irrigation for plants in containers, pots or boxes**

II. ADVANTAGES OF THE BURIED DIFFUSER

III. ANTICIPATED IRRIGATION AND WATER INJECTION AND STORAGE IN THE DEEP SOIL LAYERS OF THE PLANTATIONS USING THE BURIED DIFFUSER

- A. Concepts**
- B. Illustration**

IV. AWARDS

V. CONTACT

I. Introduction

Considering the problems of water in the Arab countries, and in the arid and semi arid regions in the world, Dr. CHAHBANI Bellachheb (senior teacher researcher in Arid Regions Institute in Tunisia), has invented a new technique for irrigation and for the injection of retention water or natural spring's water to be conserved in the deep soil horizons. This Technique is called: "**THE BURIED DIFFUSER**". It has an invention patent in Tunisia and worldwide (PCT). A Tunisian industrial and commercial company (Chahtech SA) is created to manufacture and to distribute worldwide the different types of diffusers.

The main objectives of the invention are:

- ▶ Enhance the efficiency of the water resources by using less water to produce food: "more crop per drop",
- ▶ Increasing the productivity of rain fed agriculture especially rain fed trees (olive, figs, grape, almonds, apples, and other species in the world),
- ▶ Make the rain fed agriculture sustainable taking in consideration the irregularity of rainfall: existence of humid and very humid years, short drought periods (seasonal) and long drought periods (one till three successive years),
- ▶ Conservation of the oasis and combating desertification,
- ▶ Combating soil salinization when the irrigation water contains 3 to 5 grams salts per liter.

I. Presentation of the Buried Diffuser

The diffuser for underground irrigation is a new irrigation technique that could be manufactured using several raw materials (plastic, cement, metals, ceramic etc...), but the adequate and cheapest process is plastic injection using specific moulds and plastic injection machines. The diffuser for underground irrigation is conceived for:

1. the permanent conventional irrigation of:

- ▶ trees (fruit trees, forest trees, ornamental trees) and shrubs,
- ▶ vegetables in fields and in green houses,
- ▶ plants in containers, pots or boxes,
- ▶ landscaping ,
- ▶ Annual crops such as sunflower, soybean, sugar cane, millet, sorghum, cassava, corn etc.

2. the anticipated irrigation of :

- ▶ trees (fruit trees, forest trees, ornamental trees) and shrubs,
- ▶ Annual crops such as sunflower, soybean, sugar cane, millet, sorghum, cassava, corn etc.

3. Injection and storage of water in the deep soil layers of the trees plantations.

The diffuser has several shapes and has as principal function the facilitation of irrigation water infiltration and storage in the soil in the field or in the container. The storage is done in the zone containing the great part of root system of the tree or the plant. For this facilitation, the diffuser has

specific part composed of a porous material allowing a rapid infiltration of the irrigation water. This porous material does not retain the water in the pores or on the surface of the material. This is to avoid its obstruction by the fine roots.

A. Irrigation of fruit trees, forest trees, ornamental trees and shrubs

For the Irrigation of trees (fruit trees, forest trees, ornamental trees), the diffusers are installed in pits or holes, 30 to 50 cm below the soil surface (topographic surface). It is possible to install the diffusers in the plantation pits before the installation of the tree. In this case, the diffuser should be 50 to 70 cm far from the axis of the tree. When the diffusers are added after the trees plantation, in this case they should be installed in the extremities of the canopies.

For the Irrigation of shrubs and perennial medicinal or ornamental herbs, the diffusers are installed in pits or holes 20 to 40 cm deep below the soil surface (topographic surface) and 20 cm far from the axis of the shrubs and perennial medicinal or ornamental herbs.

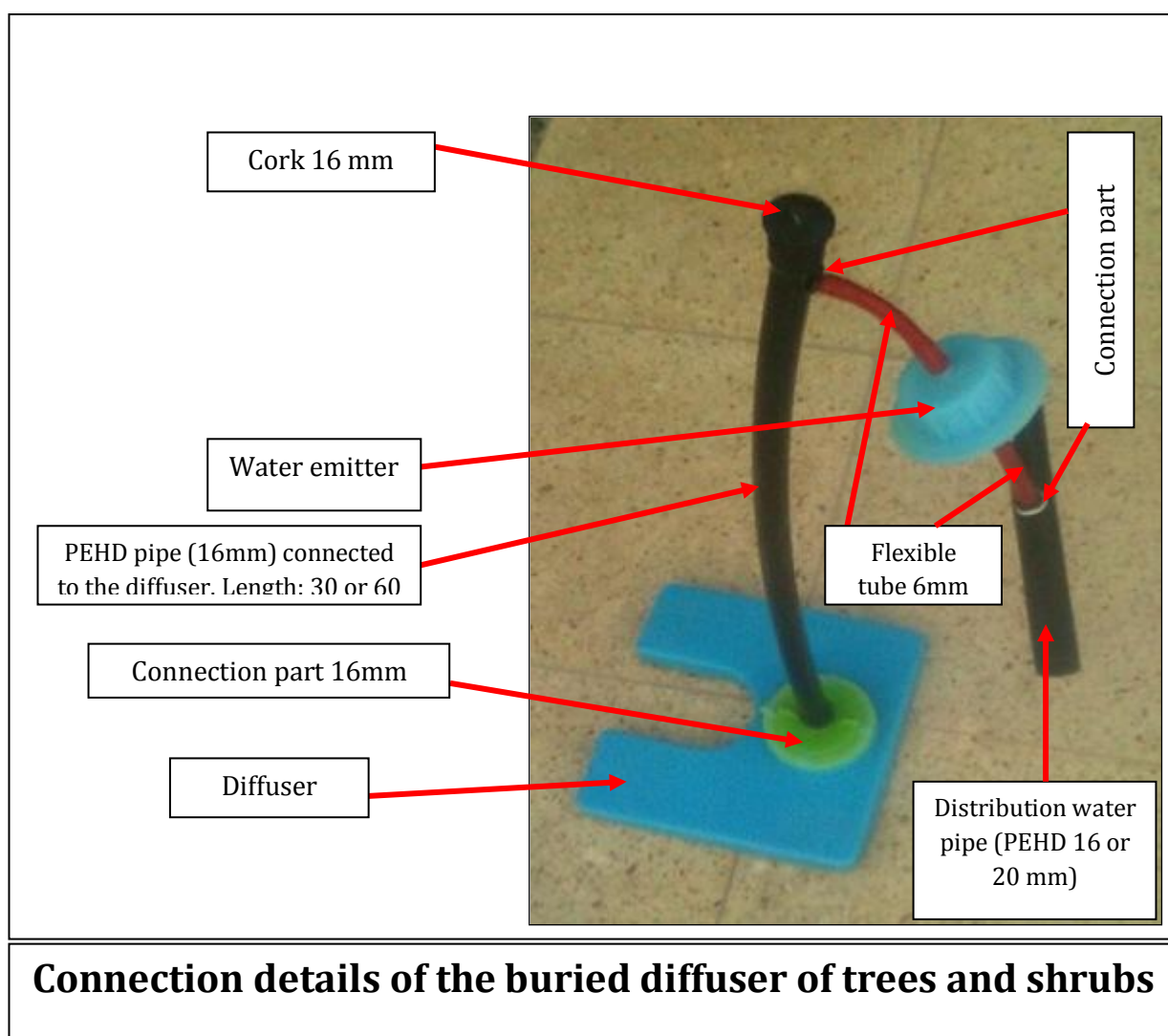

Cross section of trees irrigation with buried diffusers using gravity water flowing (from a reservoir built on the topographic soil level) and low water pressure (0,1bar)

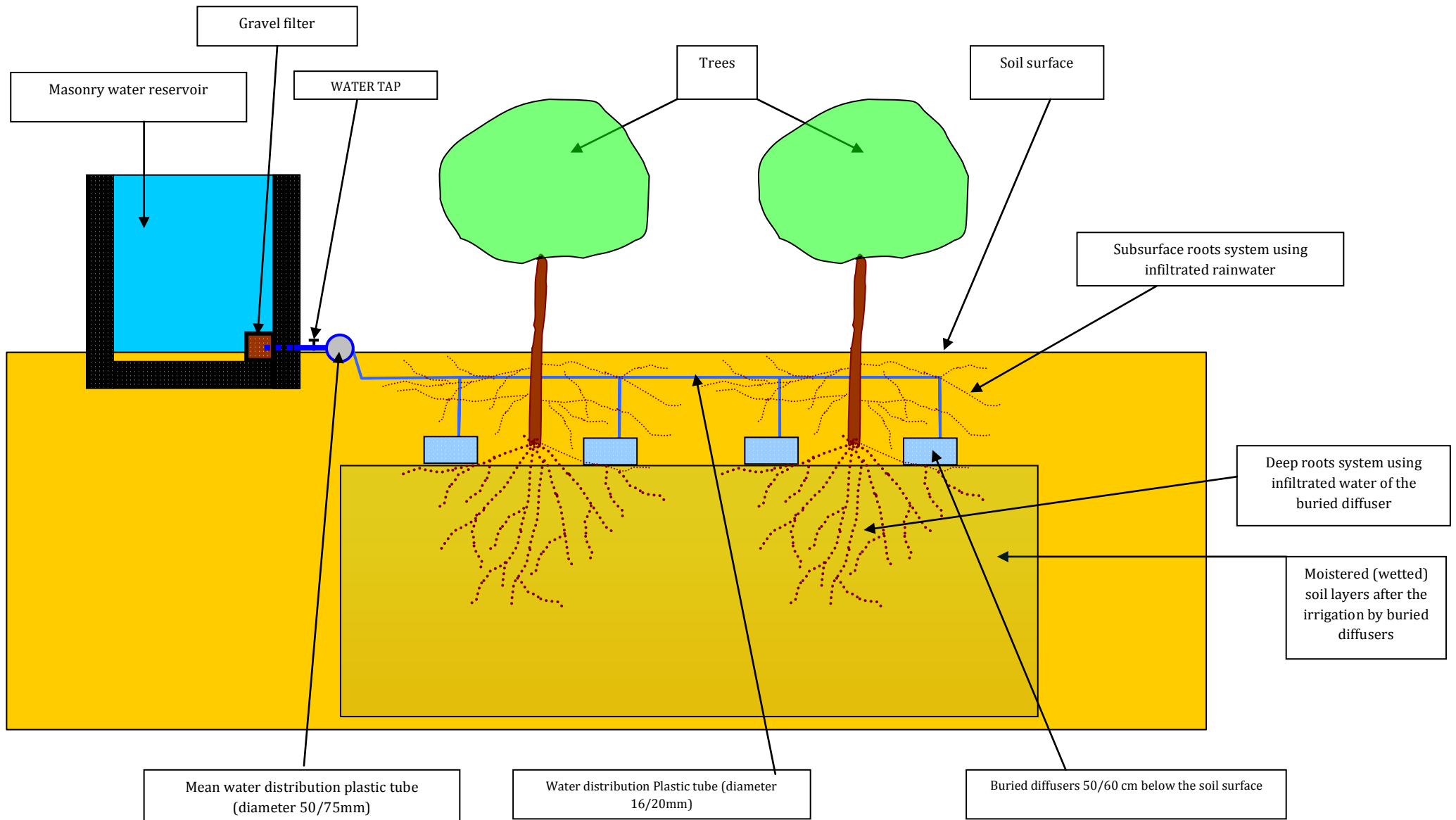

Plan view of trees irrigation with buried diffusers using gravity water flowing (from a reservoir built on the topographic soil level) and low water pressure (0,1bar)

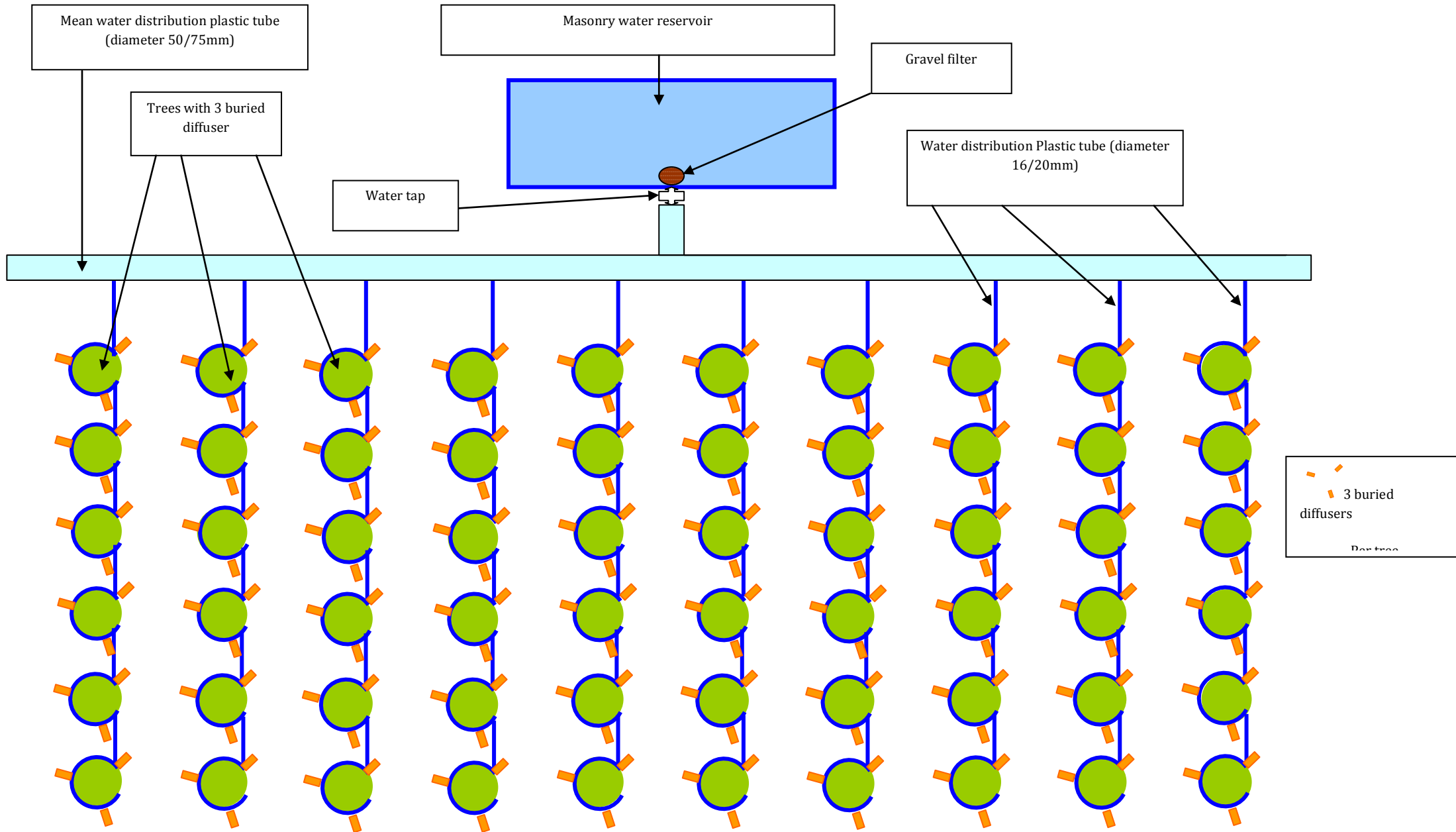

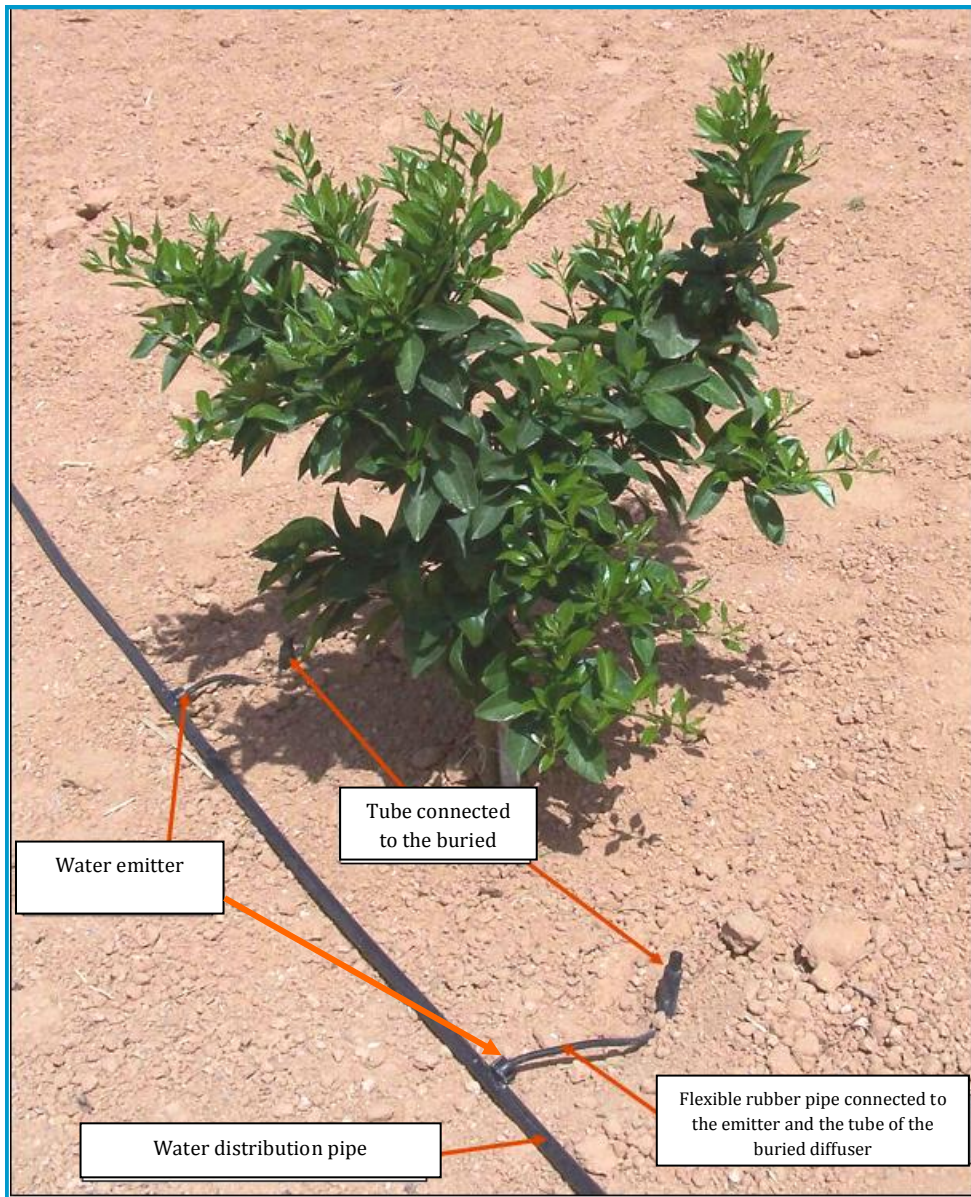

Orange tree irrigated with 2 buried diffusers in fruit trees plantation of Arid regions Institute(Medenine-South of Tunisia)

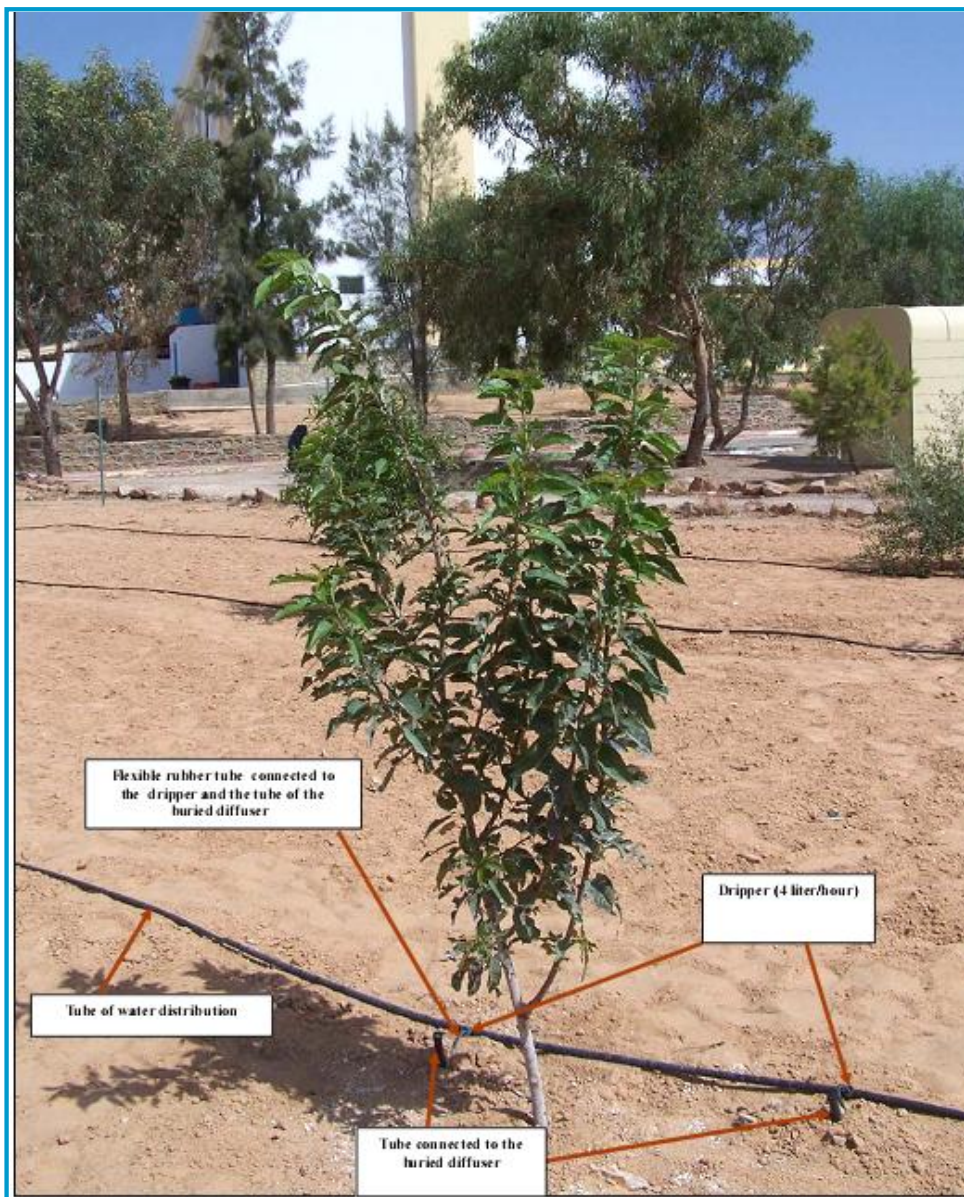

Cherry tree irrigated with 2 buried diffusers in fruit trees plantation of Arid regions Institute(Medenine-South of Tunisia)

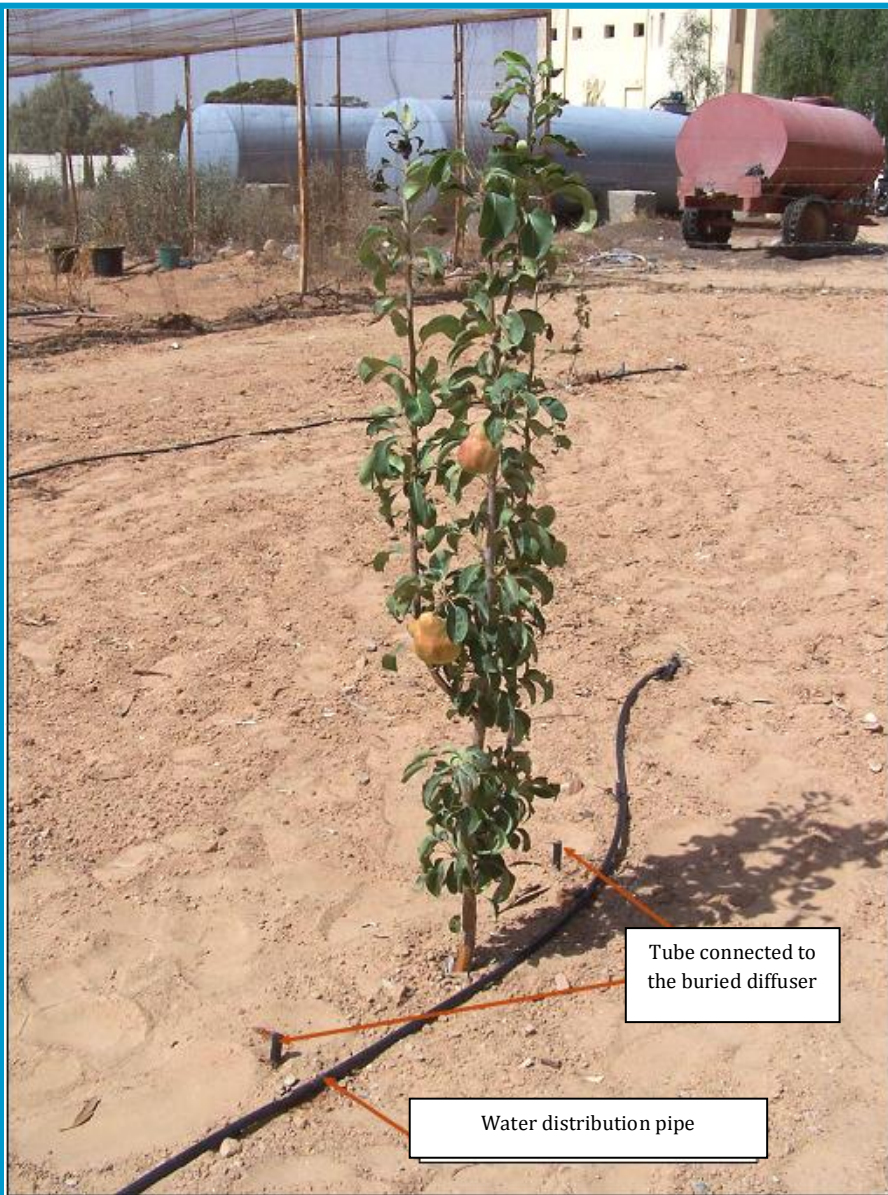

Pear tree irrigated with 2 buried diffusers in fruit trees plantation of Arid regions Institute(Medenine-South of Tunisia)

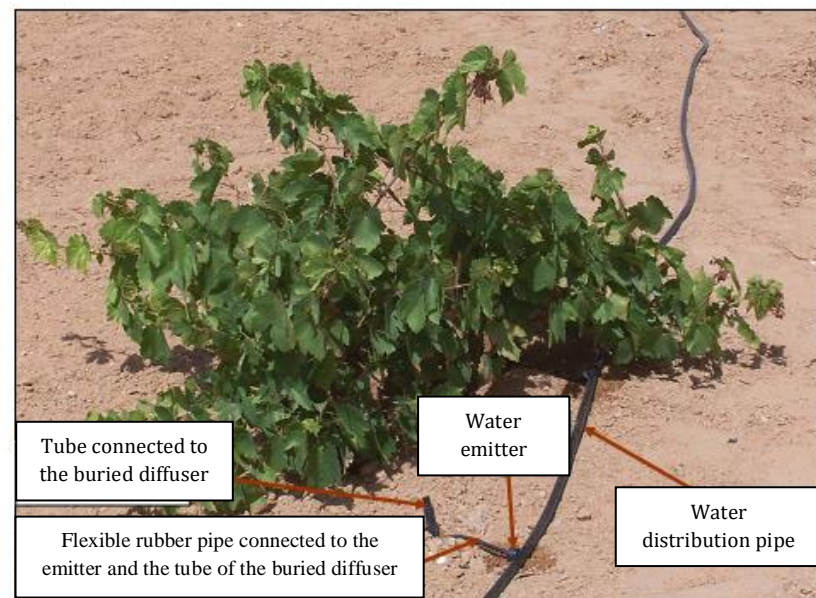
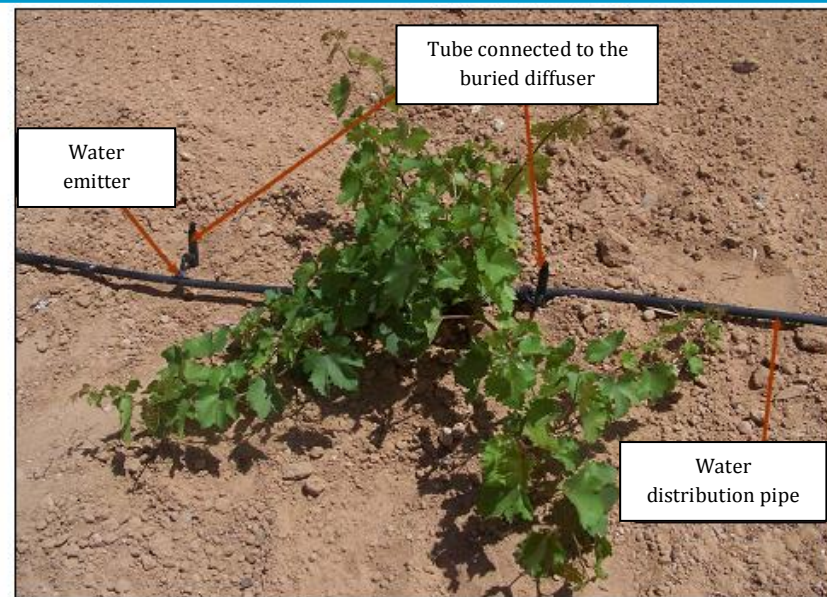

Grape tree irrigated with 2 buried diffusers in fruit trees plantation of Arid regions Institute (Medenine-South of Tunisia)

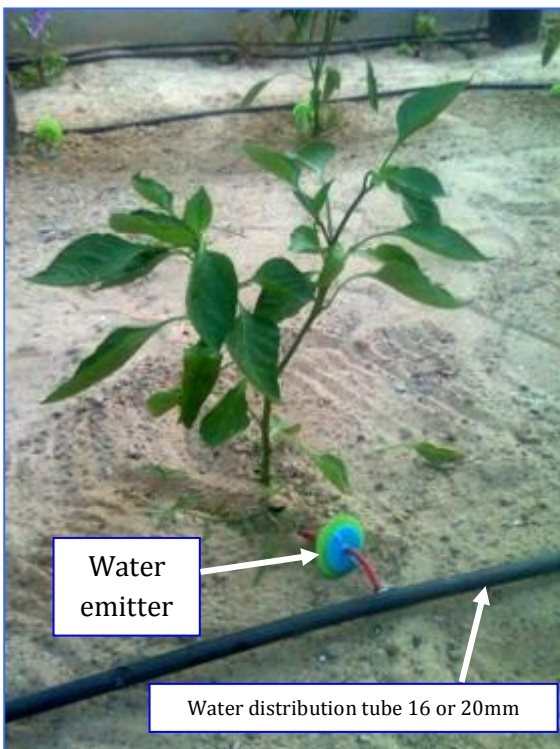

Water emitter

Water distribution tube 16 or 20mm

Mementoes irrigated with the Buried Diffuser



Private garden with pimentos and orange trees irrigated with buried diffusers

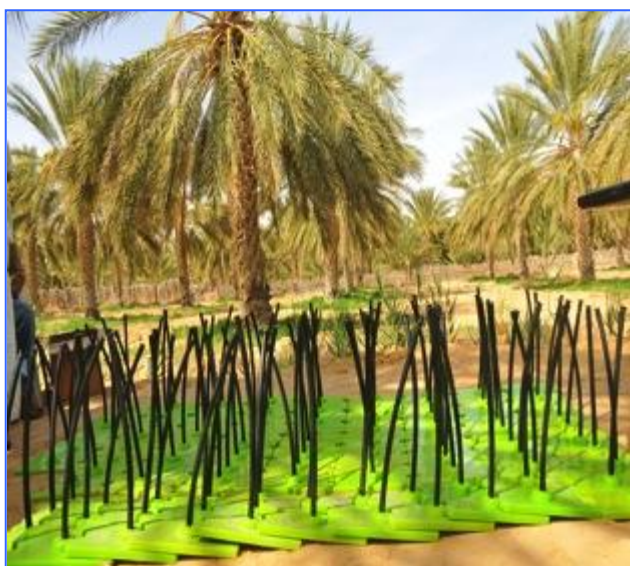

Installation of buried diffusers for dates palm trees in a private plantation in the oasis of Duos in the Desert (Kebili South of Tunisia)

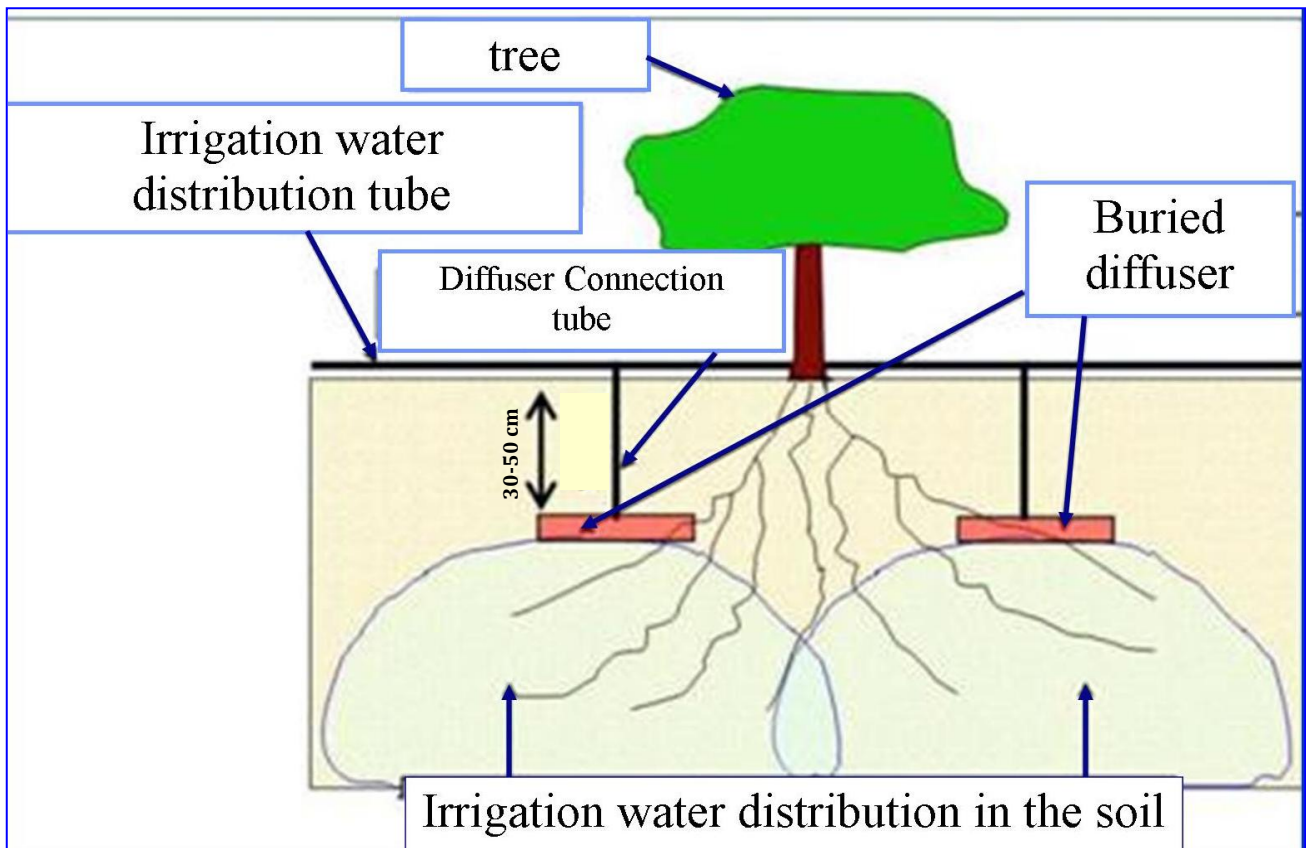

Orange tree, 3 years old, irrigated with buried diffusers
Experimental field of Arid Regions Institute-Medenine (South of Tunisia)



Buried diffuser in the pit with the 16mm connection tube



Installation of diffusers for olive trees in a private plantation in Sfax, South of Tunisia



Drilling Auger



Installation of the buried diffusers for orange trees in Beni Khaled, Cap Bon North of Tunisia

Use of drilling auger to prepare the pits (holes) for the installation of the buried diffusers for orange trees in Beni Khaled, Cap Bon North of



Young orange tree in a private garden irrigated with buried diffusers

B. Irrigation of vegetables in fields and in greenhouses

For the Irrigation of vegetables in fields and in green houses, the diffusers are installed about 3 cm far from the axis of the plant and 5 to 10 cm deep below the soil surface (topographic surface).

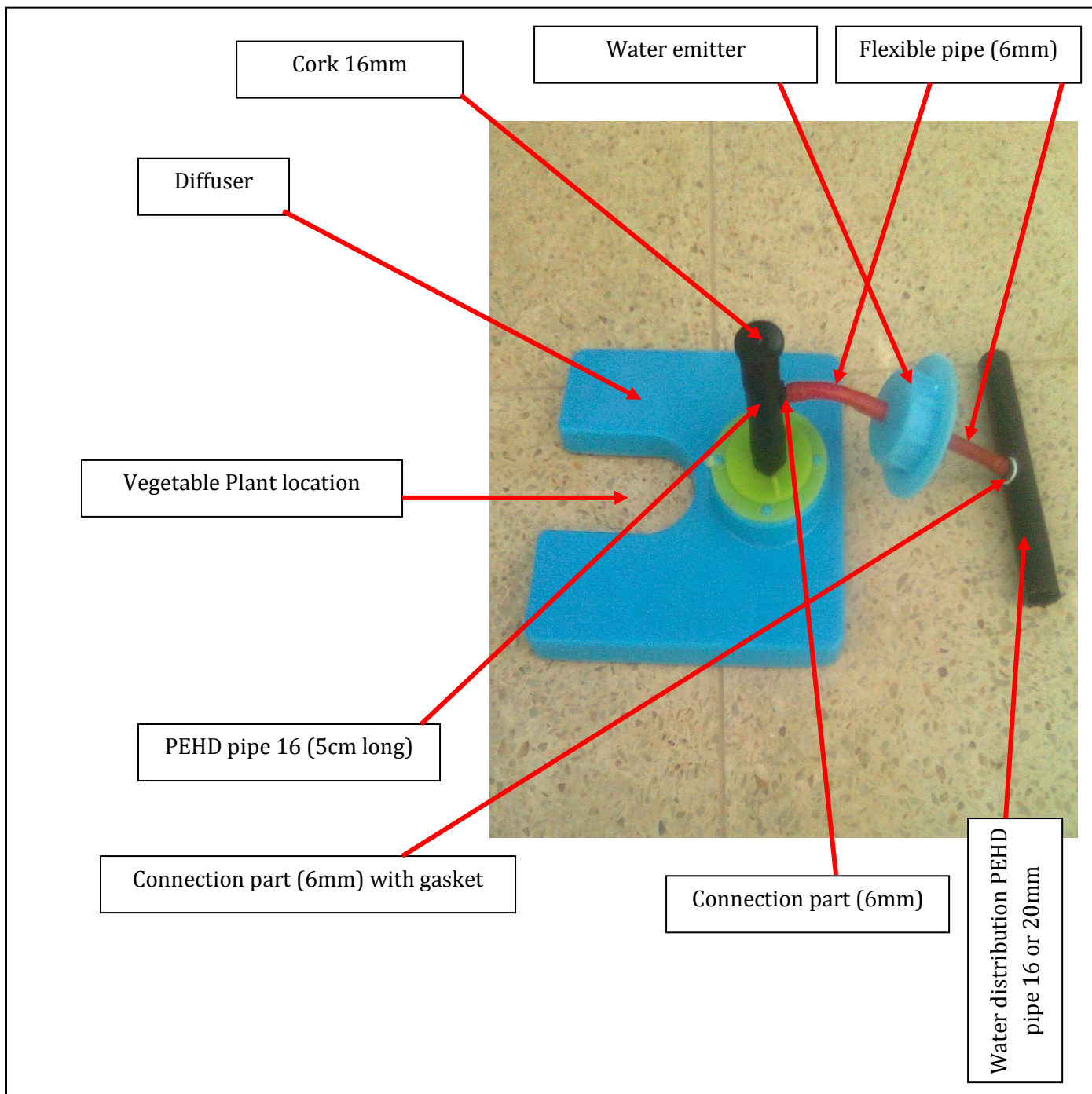

Connection accessories of the integrated water emitter for Buried Diffuser of vegetables

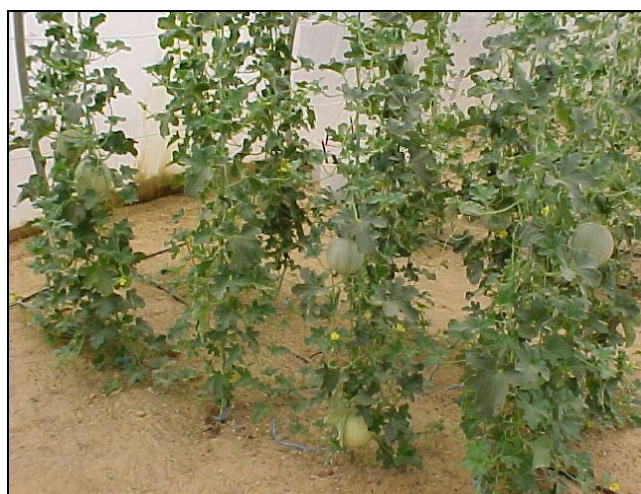
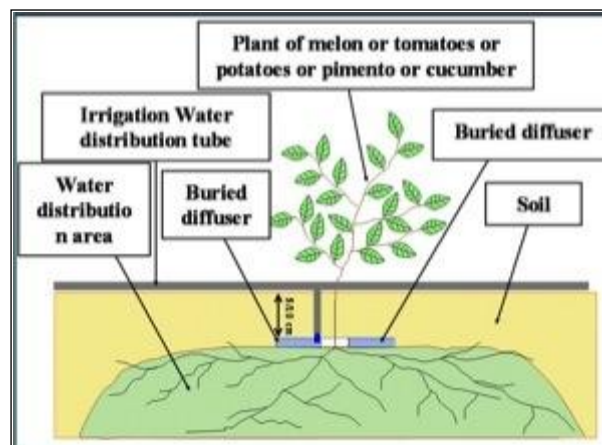

Melon and pimentos in greenhouse irrigated with prototypes of buried diffusers

Total Production in kilograms for 112 plants	Volume of irrigation water per plant in litter	Irrigation technique	Number (Plants an specie)
716	500	Buried diffuser	112 Pimentos
141.2	500	drip	112 Pimentos
382,5	250	Buried diffuser	112 Pimentos
103,7	250	drip	112 Pimentos

$$\frac{716=5}{141}$$

$$\frac{382=2,7}{141}$$

$$\frac{382=3,7}{103}$$

Trial results of comparison of irrigation by drip and by buried diffusers in the green house of farmer field in Regim Maatoug (desert of south of Tunisia)

Plan view of vegetables irrigation with buried diffusers using gravity water flowing (from a reservoir built on the topographic soil level) and low water pressure (0,1bar)

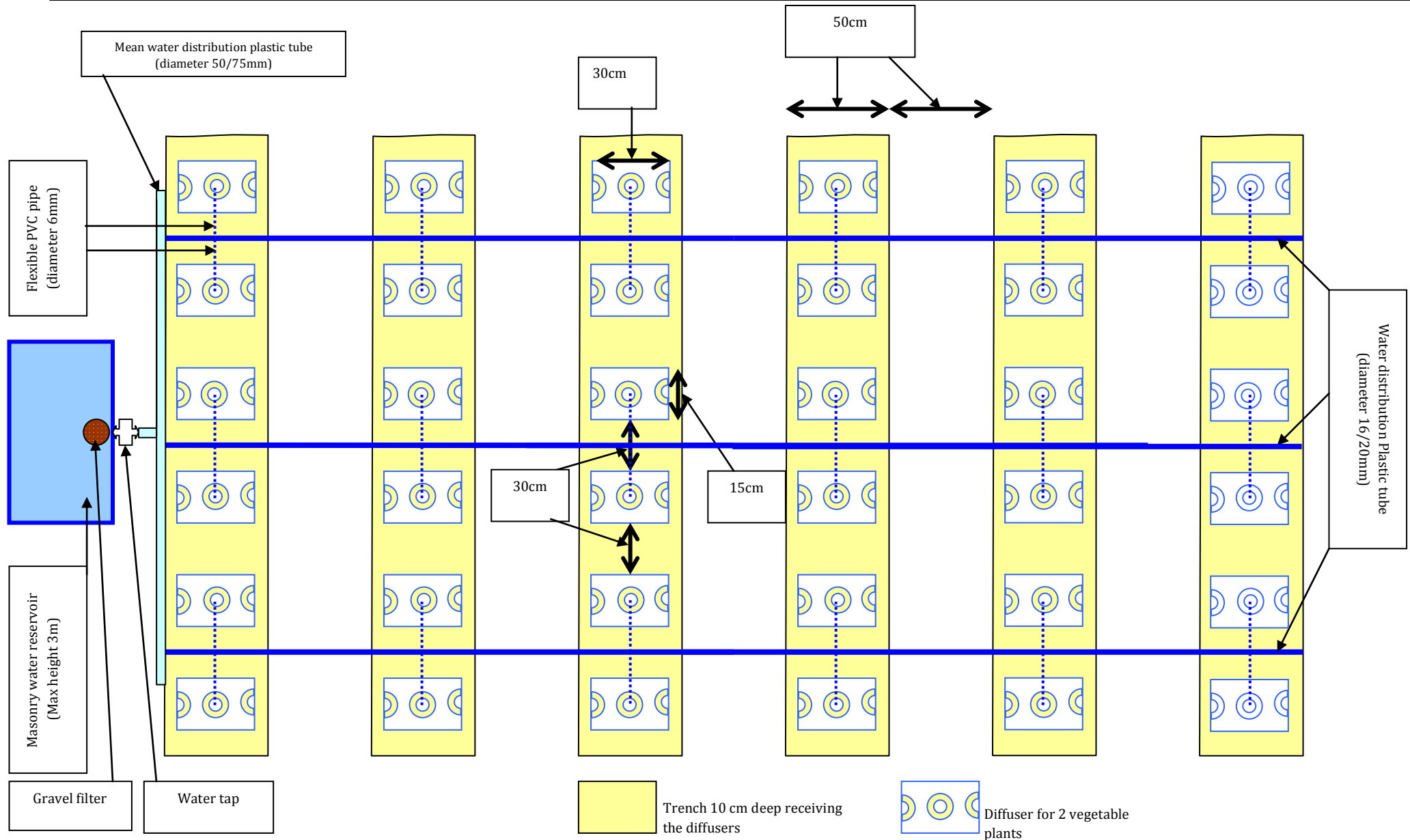

C. Irrigation for plants in containers, pots or boxes

For the irrigation of Plants in containers, pots or boxes, the diffusers include small water reservoirs to be filled during the irrigation. The capacities of the small reservoirs are few liters depending on the volumes of soil (to be completely “wetted”) contained in the containers, boxes or pots. The moisture of the container soil, after the irrigation using the diffusers, is sufficient for several days or weeks. This duration is at least 3 times longer then the existing irrigation methods (capillarity, and surface, and dripping).

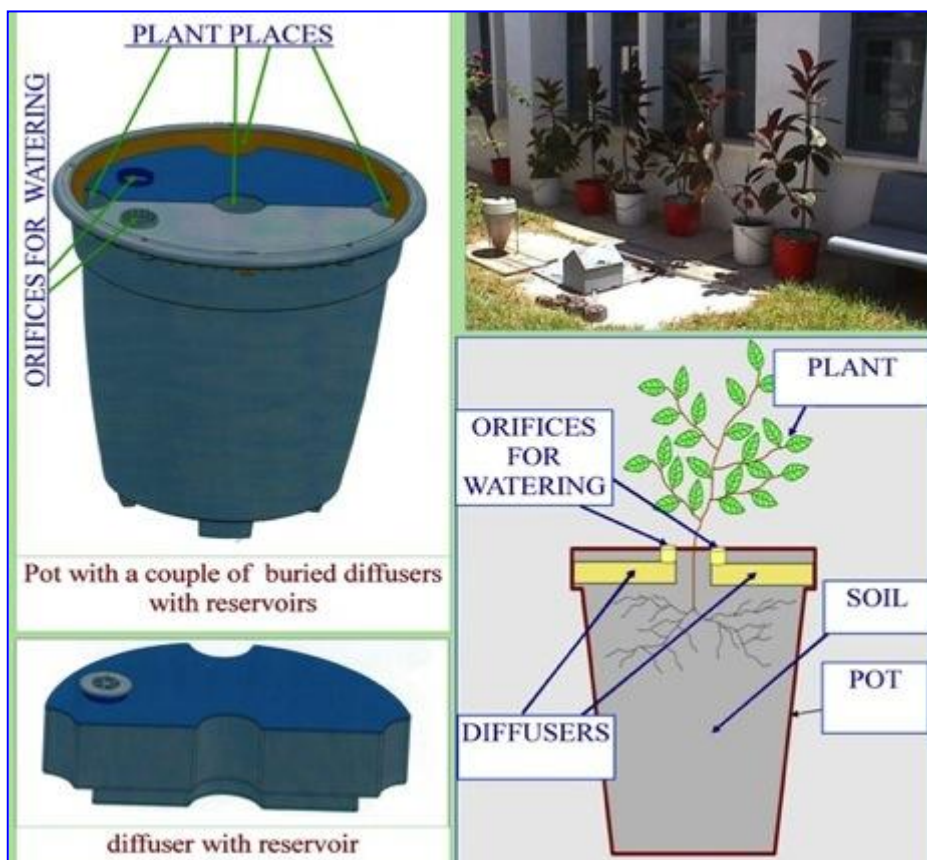

A couple of diffusers with reservoirs for pots



Pot with a couple of diffusers with reservoirs

Comparison of irrigation of ornamental plants in containers using surface irrigation and buried diffusers during the period: 15/10/2003 and 18/2/2004

Periodicity of Data survey	Irrigation method							
	Surface irrigation		Buried diffuser		Surface irrigation		Buried diffuser	
15/10/03	8925	100 %	9600	100%	9565	100%	8135	100 %
16/12/03	4890	54%	8770	91%	5240	51%	7290	89%
18/02/04	2025	22,6%	8095	84%	1970	20,6%	6585	81%

Evolution of water amounts in ornamental plants containers irrigated with surface irrigation, drip and buried diffuser, outdoor on the roof of a building-Medenine south of Tunisia

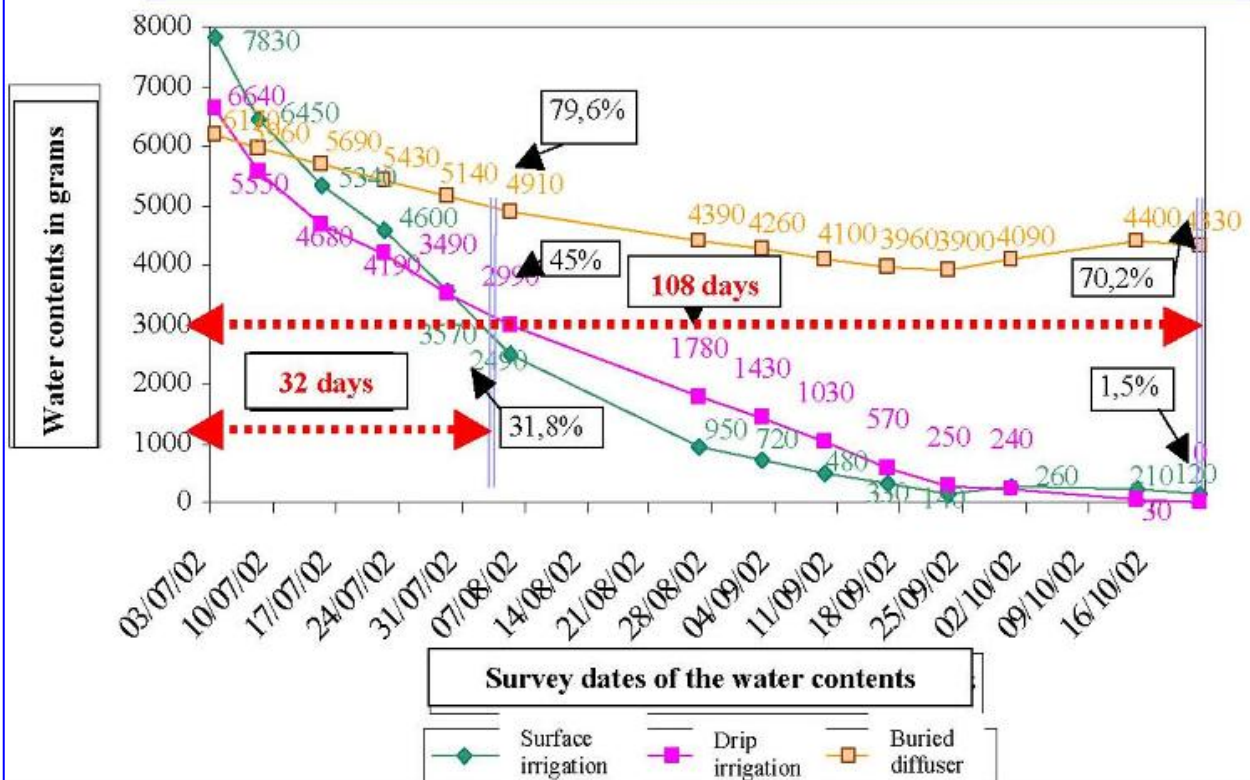

II. Advantages of the Buried Diffuser

The trial of diffuser has been done in the farmers 'fields' conditions and in the Arid Regions Institute (IRA Tunisia) experimental fields. The mean results are:

- ▶ **Great irrigation water saving:** This saving reaches 100% for the irrigation of the trees using the Buried Diffusers. The comparison of diffuser prototypes at laboratory level, outside, with surface and drip irrigation, during 2 months of summer 2003, demonstrates the superiority of the diffuser in saving water. 61 days after the irrigation, the diffuser allowed to save 34 % of the initial irrigation water amount, the surface irrigation allowed only 3,4% and the drip irrigation allowed 8%.
- ▶ **An important reduction of the number of irrigations:** This is a result of water saving which prolongs the duration between two irrigations. This was confirmed by the comparison of irrigation of ornamental plants in containers using surface irrigation and Buried Diffusers. The results of this trial show:
 - After 2 months, the water content in the containers irrigated by Buried Diffusers is 89 and 91%. For the surface irrigation the values are respectively: 51 and 54%,
 - After 4 months, the water content in the containers is: 22,6% and 20,6% for the surface irrigation, and 81% and 84% for the diffuser,
 - This means that in a programmed irrigation, when the water content in the containers reaches 50% of the field capacity, the periodicity of irrigation is 2 months for the surface irrigation and 6 months for the Buried Diffuser.
- ▶ **An important crop productivity and irrigation water efficiency:** This is demonstrated, in a farmer field in the oasis of Regim Maatoug (Desert of south of Tunisia). For full conventional water volume (500 liters per plant during the cycle), the production of 112 pimentos plants irrigated using Buried Diffusers, is 716 kilograms. When using the drip irrigation, the production of 112 pimentos plants is 141 kilograms. That means that one litter of water produces one kilogram and 432 grams for the Buried Diffuser irrigation and only 282 grams for the drip irrigation. For the same irrigation water amount the diffuser produces 4 times more than the drip irrigation.
- ▶ **Important Energy saving** by reducing the pumping time resulting from the reduction of needed irrigation water. Important energy saving at least 70% less than drip irrigation. This is a result of the reduction of the irrigation frequency and by the possibility to use the gravity (very low water pressure 1/10 to 3/10 of bar) during the irrigation. In this case the irrigation water is stored in a simple reservoir on the soil surface.
- ▶ **Reduction of water vapour** in the atmosphere inside the greenhouses. This contributes in reducing the development of diseases. This low rate of water vapour inside the greenhouses facilitates the movement of pollen and increases the rate of flowers producing fruits.

- ▶ **Important reduction of soil salinization** when using salty irrigation water (3 to 5 grams salt per liter). This reduction is estimated at 9000 kilograms per year and per hectare (with irrigation volume of 10000 cubic meters with 3 grams per liter salts, 3000 cubic meters of the volume are evaporated).
- ▶ **Better “look” of landscaping areas**, because the irrigation water distribution network could be totally buried (20 cm below the topographic surface) when using Buried Diffusers.
- ▶ **Important reduction of the air pollution** resulting from the use (for irrigation of the recreation and green areas) of treated wastewater.
- ▶ **Important reduction of:**
 - **Labour** for the maintenance of soil: weeds pulling out, irrigation frequency, mulching actions, etc.
 - **Fertilizers** amounts, because there is less degradation of the fertilizers and less loss by leaching, this reduces the pollution of the ground water by the leaching chemical components.
 - **Herbicides and pesticides** because there are no weeds in the irrigation by the Buried Diffuser (for vegetable fields and trees plantations), this is a great contribution in the protection of the environment.

III. Anticipated irrigation and Water injection and storage in the deep soil layers of the plantations using the Buried Diffuser

A. Concepts

After the use of the buried diffuser for the regular irrigation, Chahtech SA has created a new method for “anticipated irrigation” and “water injection in the deep soil layers”. The goal of this new concept is **to save and conserve the huge of water received during the wet season, for the next dry season.**

More than that, in other regions of the world the challenge is higher: how to save and conserve the huge of water received during the wet or rainy years to be used during the long dry period: one till 3 years.

Both “anticipated irrigation” and “water injection” are solutions for drought mitigation and for climate change adaptation.

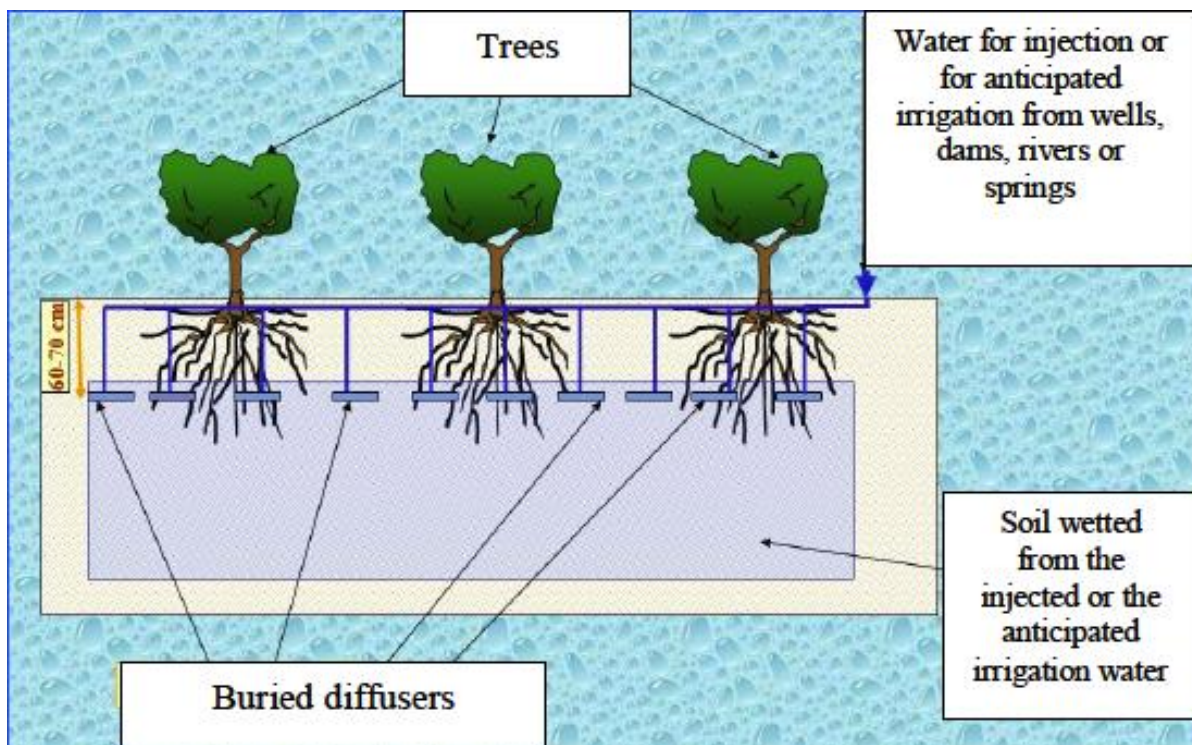

Figure 1 – Cross section of “Anticipated Irrigation” or “Water Injection” system using Buried Diffusers

► Anticipated Irrigation

For the “anticipated irrigation”, instead of irrigation during the hot or the dry season, the irrigation using buried diffusers is done during the autumn and winter or during the rainy season. The amount of water of the “anticipated irrigation” should cover the total need of the crop during the hot or dry season (spring and summer). This water amount is stored in the deep soil layers will be used by the deep or sub surface roots systems of the crops.

► Water injection in the deep soil layers

The “water injection in the deep soil layers” is useful especially for trees crops. The injected water comes from: dams, rivers, and springs. The amount of the injected water could cover the need of the trees for several years (2 to 3years) when the soil below 50cm is thick (1 meter or more). This injected water is conserved (stored) in the deep soil layers (50 cm below the soil surface) and used later by the deep root systems of the trees during a long drought period: six months till 3years. During the Drought the trees produce normally using the injected and stored water.

According to long injection period (15 days to 90 days none stop: days and nights), it is recommended to use our “energy less” system of water “pumping” and distribution using the gravity. This system uses our second product: “the draining floater”. This system is described in another report which could be downloaded from our website: www.chahtech.com .

B. Illustration

The lost water during 1 rainy and 1 very rainy year is 1 550 000 Cubic meters. This volume could be injected, using buried diffusers, and stored in deep layers of the soil. The injection of 1 550 000 is sufficient to maintain in good conditions of production 34 444 adult olive trees, during 3 dry years (each tree has 15 Cubic meters per year). This water stored in deep soil layers is very important for the trees plantations used to be irrigated yearly and suffer from long drought (2 till 3 years).

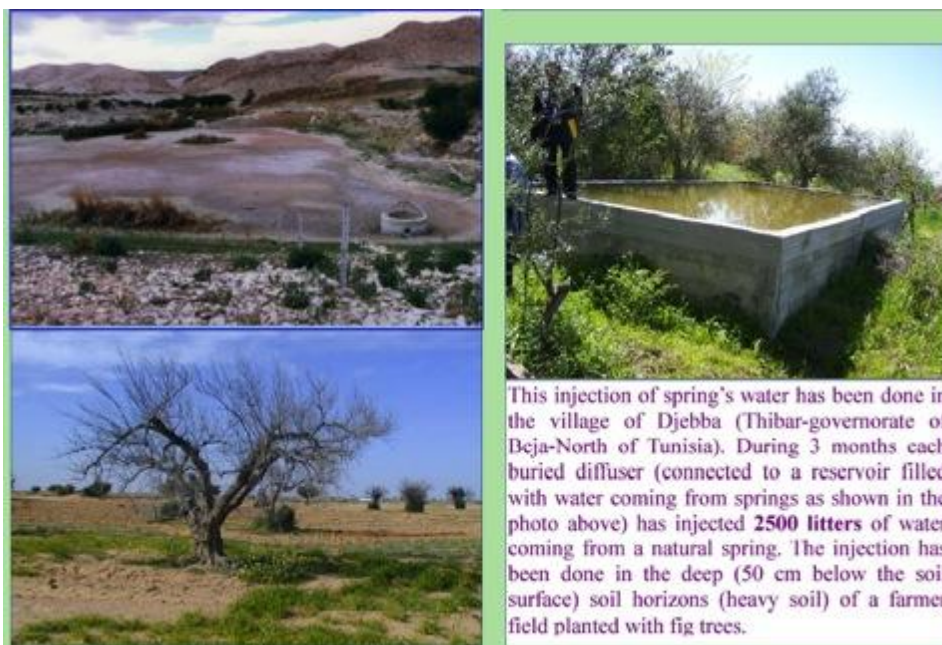

The water flowing from the natural springs and not used during the autumn, winter and the beginning of the spring is lost in the rivers. This lost water is estimated 23 328 m³ (from September till May) for a spring with a flow of 1 liter/second. If this volume is injected in the soil horizons, using buried diffusers; it is sufficient for the water needs of about 518 adult olive trees during 3 years (without any rain).



Figure 2 - Installation of Buried Diffusers for spring's water injection (stored in a concrete reservoir) in the deep soil layers of figs' trees plantation in Djebba (Beja Governorate in North West of Tunisia)

IV. Awards

The Buried Diffuser is a worldwide patented (PCT) invention, which was awarded multiple times. Below some of these awards:

- ▶ Prize of the Grand Price INNOVATEC 2012/2013, MIFFEL, Avignon, France. 2012
- ▶ TOP 20 innovative SME (Small to Medium Enterprises) of Infolded, World Bank, Helsinki, Finland.
- ▶ 2011 UNESCO international water prize, Budapest, Hungary. 2009
- ▶ Creativity price awarded by the Presidency of the Republic of Tunisia. 2009
- ▶ Maghreb union combating desertification Technologies Prize. 2007
- ▶ ALESCO Price (Arab League of Education, Culture and Science) of scientific innovation in the field of water. 2002
- ▶ Two silver medals for two inventions - 30th International Exhibition of Inventions, Geneva, Switzerland. 2002
- ▶ National Merit Medal (Commander) under the sector of Education and Science, Tunisia. 2001
- ▶ First prize of the Tunisian Association of Inventors for researchers inventors granted by the Tunisian Association of Inventors at the 11th National Competition of Invention and Innovation, Tunisia. 2001
- ▶ First prize of the WIPO (World Intellectual Property Organization) for the best invention by an inventor researcher at the 11th National Competition of Invention and Innovation. Tunisia. 2001
- ▶ First prize in the "Mediterranean Prize for Water" award from the Carrefour Euro Mediterranean
- ▶ Water HYDROTOP Second prize of Technology Innovation International Fair of Agriculture and Technology Innovation SIAT. Tunisia. 2000
- ▶ ...

V. Contact

Please don't hesitate to visit our website for more details: www.chahtech.com. You can also contact us:

- ▶ Mail: contact@chahtech.com
- ▶ Mobile: +216 98 254 383
- ▶ Tel/Fax: +216 75 654 391